



APPLICATION FOR CERTIFICATE OF APPROPRIATENESS

Send completed application and check to: Meridian Street Preservation Commission 200 E. Washington Street, Suite 1821 Indianapolis, IN 46204

MSPC Case No.: MSPC 16-09

Address of the Property where work is to be done:

5140 N. Meridian

Applicant's Name:

Aimee Kandrak & Brett Yockey

Phone No:

317 579 9389 - Brett

Address:

FAX No:

E-Mail address:

Zip Code:

Name of Owner(s):

Aimee Kandrak & Brett Yockey

Phone No:

317 579 9324 Aimee

Address of Owner:

5140 N. Meridian

FAX No:

E-Mail address:

aimee.kandrak@gmail.com

Zip Code:

46208

Brett.yockey@gmail.com

The present Use of the property is:

Residential / Single Family / Primary

The current Zoning Classification of the property is:

Will the Use change under the proposed work? [ ] Yes [X] No If yes, to what?

The work being proposed will be on/for (check all that apply):

- Renovation or Remodel of Accessory structure (checked)
New building, Renovation or Remodel of Primary structure, Site Work/Landscaping, Demolition of Primary structure, Demolition of Accessory structure

Detailed Description of work to be done (attached additional sheets if necessary):

Remove existing unsightly, leaking solarium. Construct new, quality solarium, with quality materials and construction methods. removal of collapsing fence

The work will be done by: [ ] Owner [X] Contractor [ ] Other

Contractor's Name: TT Reparatations

Phone: 317-445-3210

Date of start: ASAP

Date of completion:

Documentation submitted (10 copies required of any information submitted):

- Site Plan, legible & drawn to scale (required) (checked)
Building plans, elevations (required) (checked)
Drawings/Sketches (checked)
Photographs (required) (checked)
Samples/Swatches (checked)
Other (checked)

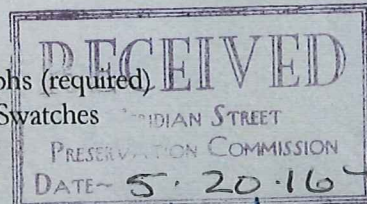

I (we) affirm, under the penalties for perjury, that the foregoing representations are true

Signature of Owner

Date: 5/20/16

Signature of Applicant (if different than Owner)

Date

Kandrac-Yockey Residence  
 5140 N. Meridian Street, Indianapolis  
 18 May 2017 3/32" = 1'-0"

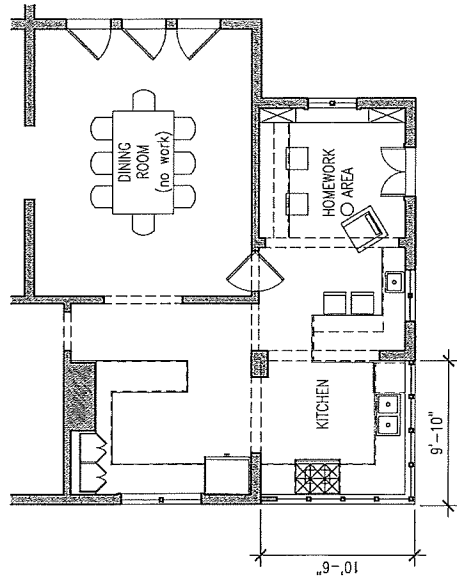

Partial Floor Plan  
 (no work rest of house)

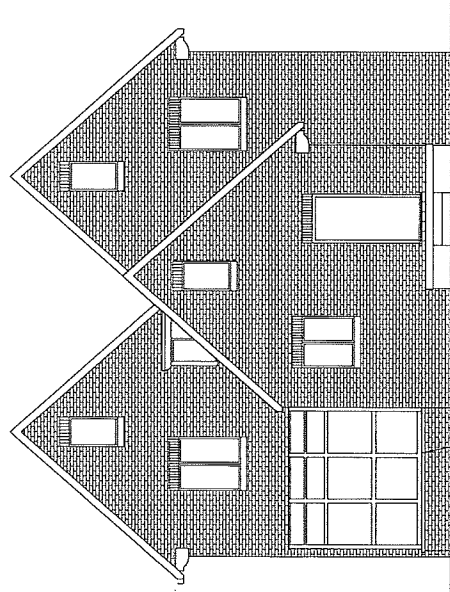

Exg. West Elevation

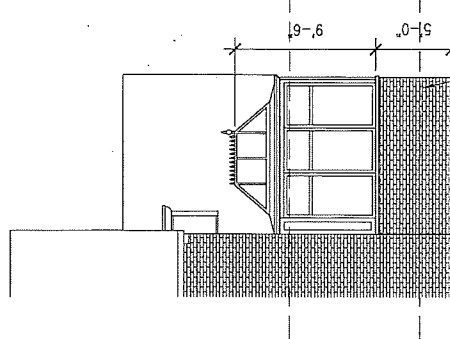

North Elevation (Side Yard)

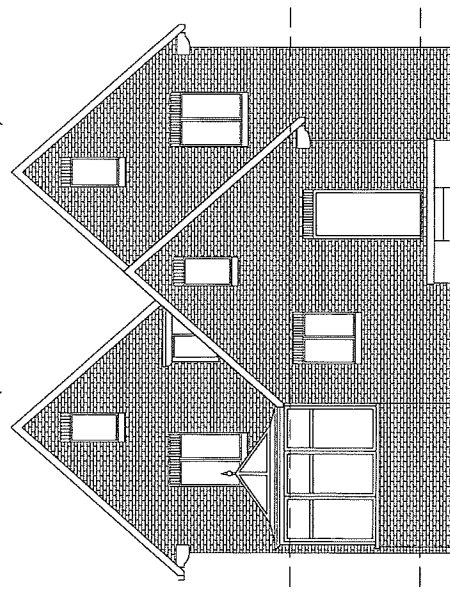

West Elevation (Backyard)